



Acousto-Optic Deflector Driver

Including: Basic Deflector Alignment

Instruction Manual

RFA910T Series

Models -

RFA910T-30	: 20-40MHz	10V Tuning Input, 10V Analog Modulation Input
RFA910T-40	: 30-50MHz	10V Tuning Input, 10V Analog Modulation Input
RFA910T-80	: 60-100MHz	10V Tuning Input, 10V Analog Modulation Input

ISOMET CORP, 5263 Port Royal Rd, Springfield, VA 22151, USA.
Tel: (703) 321 8301, Fax: (703) 321 8546, e-mail: isomet@isomet.com
www.ISOMET.com
ISOMET (UK) Ltd, 18 Llantarnam Park, Cwmbran, Torfaen, NP44 3AX, UK.
Tel: +44 1633-872721, Fax: +44 1633 874678, e-mail: isomet@isomet.co.uk



1. GENERAL

The RFA910T combined Driver and Power Amplifier, Figure 1, is a modular, swept-frequency RF power source specifically designed to operate with Isomet acousto-optic deflectors. The driver accepts a tuning voltage between approximately +0 volts and +10 volts and provides an RF output to at the selected frequency. The driver also accepts an analogue modulating signal and generates a modulated RF output to the acousto-optic deflector. This provides for intensity control across the scan range.

A summary of the driver specification is shown in the following table:

<u>Model</u>	<u>Output Frequency</u>	<u>Output Power</u>
RFA910T-30	20 - 40MHz	> 10.0 Watt
RFA910T-40	30 - 50MHz	> 10.0 Watt
RFA910T-80	60 - 100MHz	> 10.0 Watt

Figure 2 is a block diagram of the Driver. The output frequency of the driver is controlled by a hybridized varactor voltage controlled oscillator. The output frequency is proportional to the input tuning voltage with a scale factor of approximately 2 - 4MHz/volt depending on the model. The start frequency corresponding to a tuning voltage of 0.0 volts is defined by the frequency offset potentiometer (Multi-turn pot to the right of the LED's) This permits adjustment of the start frequency from approx -5% / +90% of the range. The start frequency corresponds to a tuning voltage of 0.0 volts and is pre-set to a start frequency as listed above. A table of output frequency versus input tuning voltage is supplied with each driver and is pseudo-linear. The frequency linearity is typically less than $\pm 2.0\%$, and frequency stability is typically $\pm 0.25\%$.

A high-frequency, diode ring mixer is used to amplitude-modulate the RF carrier. A "video" modulation input swing of 10volts (positive with respect to ground) will result in 100% depth of modulation. Figure 3 shows the modulation control.

The video input level must not exceed 20 volts



The amplitude-modulated RF signal is input to a Class A power amplifier stage. This amplifier is designed to operate at full rated power into a 50Ω load with 100% duty cycle.

Ensure adequate air flow across the heatsink.

The heatsink temperature must not exceed 70°C.

**SERIOUS DAMAGE TO THE AMPLIFIER MAY RESULT IF THE TEMPERATURE EXCEEDS 70°C.
SERIOUS DAMAGE TO THE AMPLIFIER MAY ALSO RESULT IF THE RF OUTPUT CONNECTOR
IS OPERATED OPEN-CIRCUITED OR SHORT-CIRCUITED.**

A DC power supply is required for operation of the RFA910T. The required voltage is +15Vdc ** at a current drain of approximately 1.8A. The external power source should be regulated to ± 2% and the power supply ripple voltage should be less than 100mV for best results.

The output power level is set by the power adjust potentiometer (PWR ADJ)

NOTE : Maximum power = fully clockwise

2. LED INDICATORS

- Lower Green LED:

Shows GREEN when the RF output is live, PROVIDED:

- a) the modulation duty cycle is more than 20% (approx).
- b) the RF CW power is > 20% (approx) of the driver maximum power
- c) Red LED is on

- Upper Red LED:

Shows RED when the DC power is applied AND the AO and Driver Thermal Interlocks are good

** Note:

The driver will operate from +24Vdc with a small increase in output power but increased thermal dissipation



3. INSTALLATION AND ADJUSTMENT

(See Figures 4 & 5)

3.2 With no d-c power applied, connect the + 15Vdc in to the center terminal of the feed-thru terminal 1. DO NOT APPLY POWER.

3.3 Connect the RF output SMA jack to the SMA or BNC RF input of the acousto-optic deflector (or a 50Ω RF load, if it is desired to measure the modulator RF output power).

3.4 Connect the amplitude control source to the the D-type connector.

- Connect the modulation signal (0,0 - 10.0V) to pin 8
- Connect the signal return (0V) to pin 3

To begin, apply a constant voltage of 10.0V.

3.5 Connect the external Interlock of the acousto-optic modulator (if fitted) to the enable inputs on the 9-pin D-type connector. If no interlock is fitted then these inputs MUST be connected together.

- Connect pin 9 to the floating contact 1 of the interlock switch.
- Connect pin 4 to floating contact 2 of the interlock switch. (Grounded at driver)

The interlock connection becomes open circuit disabling the RF output, if the temperature of the modulator exceeds 30°C or the internal driver temperature exceeds 70°C. An LED indicator illuminates when the Interlocks are closed and the RF is enabled.

3.6 If required apply a 12V CMOS compatible or open collector driver to the Digital Gate input.

- Connect the tuning signal (12v maximum) to pin 7
- Connect the signal return (0V) to pin 2

This input is optional and may be left NC (Not Connected).

A closed contact on this input will disable the RF Output. Switching response time 10msec.

3.7. Connect the tuning voltage source to the the D-type connector

- Connect the tuning signal (0,0 -10.0V) to pin1
- Connect the signal return (0V) to pin 6

3.8 Adjustment of the RF output power is best done with amplifier connected to the acousto-optic modulator

The optimum RF power level required for the modulator to produce maximum first order intensity (or minimum zero order intensity) will be different at various laser wavelengths. Applying RF power in excess of this optimum level will cause a decrease in first order intensity (a false indication of insufficient RF power) and makes accurate Bragg alignment difficult. It is therefore recommended that initial alignment be performed at a low RF power level.

- 3.9 Locate the PWR ADJ. Single turn pot on the left side of the access aperture.
- 3.10 With an insulated alignment tool or screwdriver rotate the PWR ADJ potentiometer fully anti-clockwise (CCW) i.e.OFF, then clockwise (CW) approx 1/2 turn.
- 3.11 Apply + 15V DC to the amplifier.
- 3.12 Apply a 10.0V constant modulation signal to the modulation input, pn 8 of the D-type connector.
- 3.13 Apply a 5.0V constant tuning voltage to the tuning input, pn 1 of the D-type connector. This will operate the deflector at its mid-scan position.
- 3.14 Align the deflector head to insure that the incident light beam is centred in the active aperture of the deflector. The following explanation assumes the light beam is directed slightly toward the transducer (connector end) of the deflector

Observe the diffracted first-order output from the acousto-optic modulator and the undeflected zeroth order beam. Adjust the Bragg angle (rotate the deflector) to maximise first order beam intensity.

- 3.15 After Bragg angle has been optimized, slowly increase the RF power (rotate PWR ADJ CW) until maximum first order intensity is obtained. Record this intensity value (I_{SAT}).
- 3.16 To equalise deflection efficiency across the extremes of the scan, alternate between the minimum and maximum desired frequencies (0.0V and 10.0V tuning voltage resp.) and adjust the Bragg angle to give the same efficiency at both positions. Fine tuning of the incident Bragg angle and RF power may be necessary for optimum results.
- 3.17 The RFA910T is now ready for use as a variable frequency AO driver.



4. MAINTENANCE

4.1 Cleaning

It is of utmost importance that the optical apertures of the deflector optical head be kept clean and free of contamination. When the device is not in use, the apertures may be protected by a covering of masking tape. When in use, frequently clean the apertures with a pressurized jet of filtered, dry air.

It will probably be necessary in time to wipe the coated window surfaces of atmospherically deposited films. Although the coatings are hard and durable, care must be taken to avoid gouging of the surface and residue of the cleaning solution. It is suggested that the coatings be wiped with a soft ball of brushed (short fibres removed) cotton, slightly moistened with clean alcohol. Before the alcohol has had time to dry on the surface, wipe again with dry cotton in a smooth, continuous stroke. Examine the surface for residue and, if necessary, repeat the cleaning.

4.2 Troubleshooting

No troubleshooting procedures are proposed other than a check of alignment and operating procedure. If difficulties arise, take note of the symptoms and contact the manufacturer.

4.3 Repairs

In the event of deflector malfunction, discontinue operation and immediately contact the manufacturer or his representative. Due to the high sensitive of tuning procedures and the possible damage which may result, no user repairs are allowed. Evidence that an attempt has been made to open the optical head will void the manufacturer's warranty.

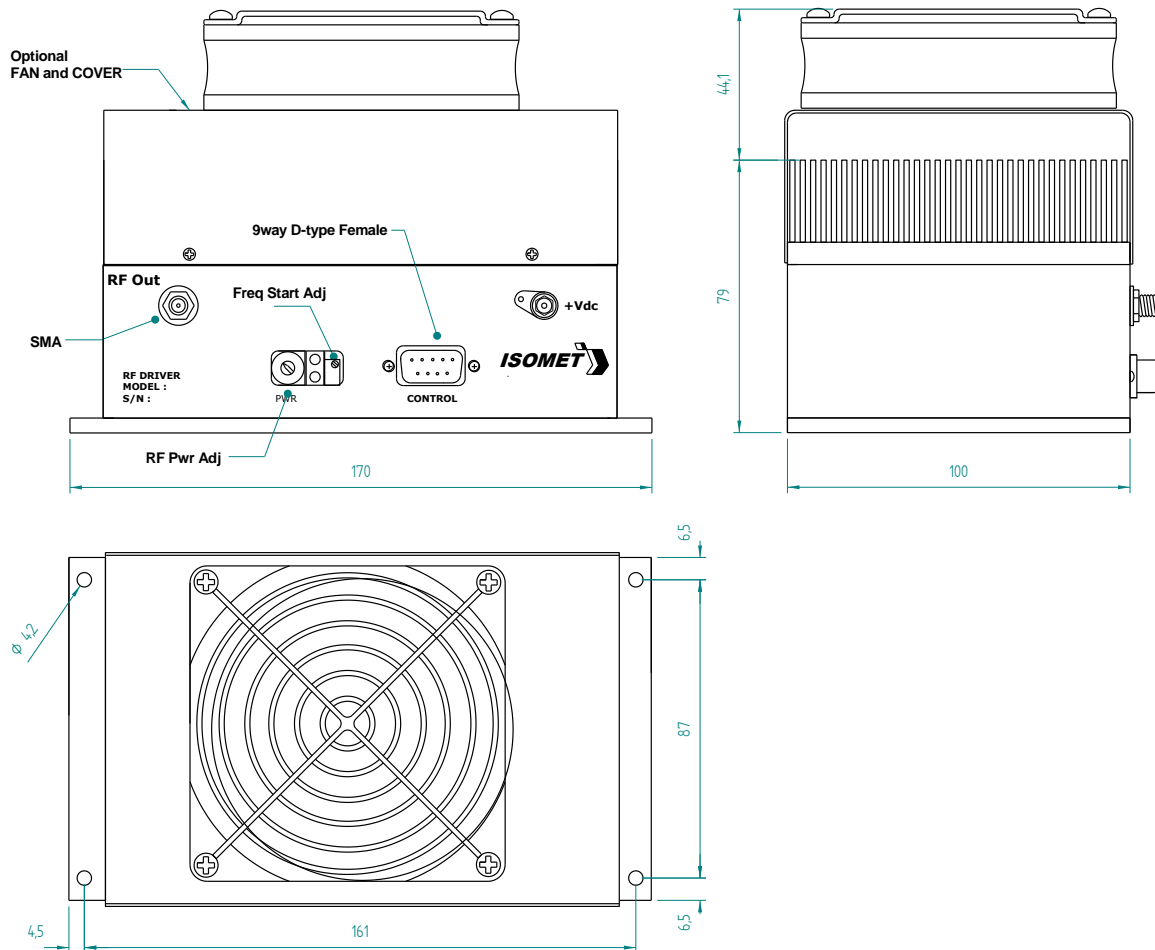

Control signals -	:	9 pin 'D' type
Tuning Voltage (0 -10V)	:	+sig pn1, -rtn pn6
Amplitude Control (0 – 10V)	:	+sig pn8, -rtn pn3
Enable/Interlock Control (Low = On)	:	+sig pn9, -rtn pn4
Digital Gate Input (NC or High = On)	:	+sig pn7, -sig pn2
Internal 10K ohm pull up to 12V		

DC supply connection for older drivers fitted with solder feed through

CENTRE PIN +15Vdc
(Ignore drawing label)

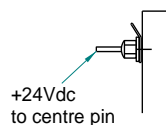

Tag or threaded case stud = 0V connection

Fig 1: RFA910T (with optional Fan and cover)

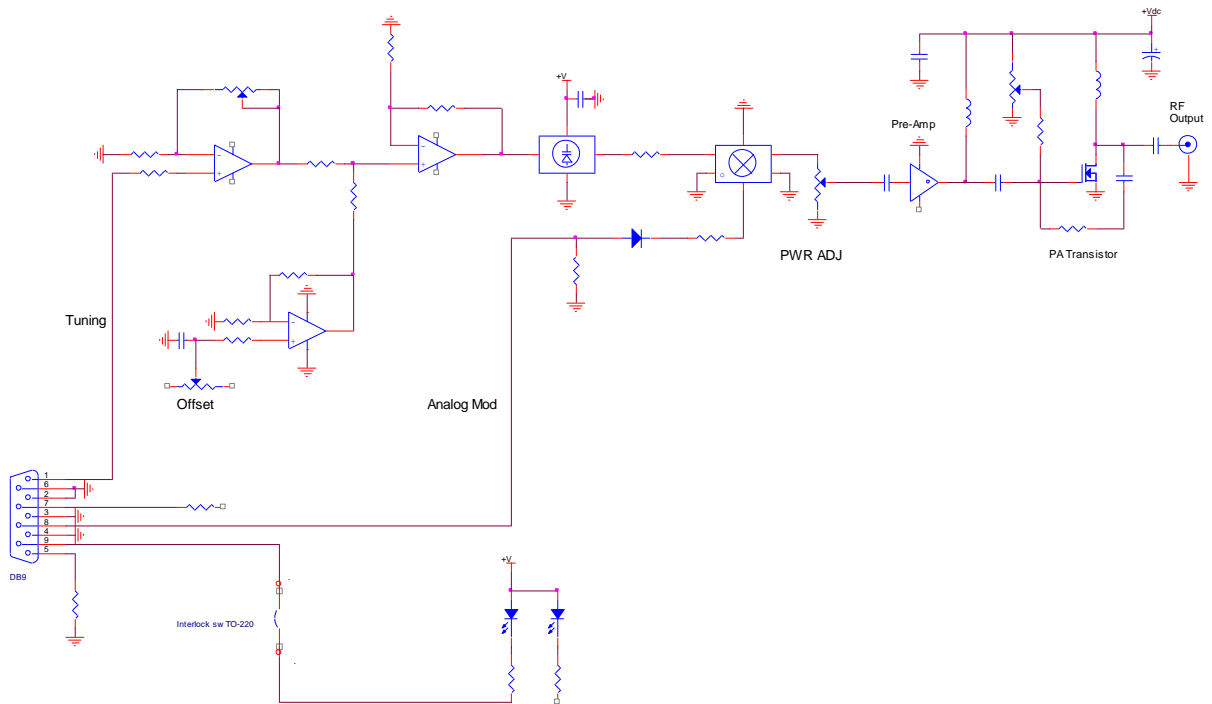

Figure 2a: Driver block diagram (generic)

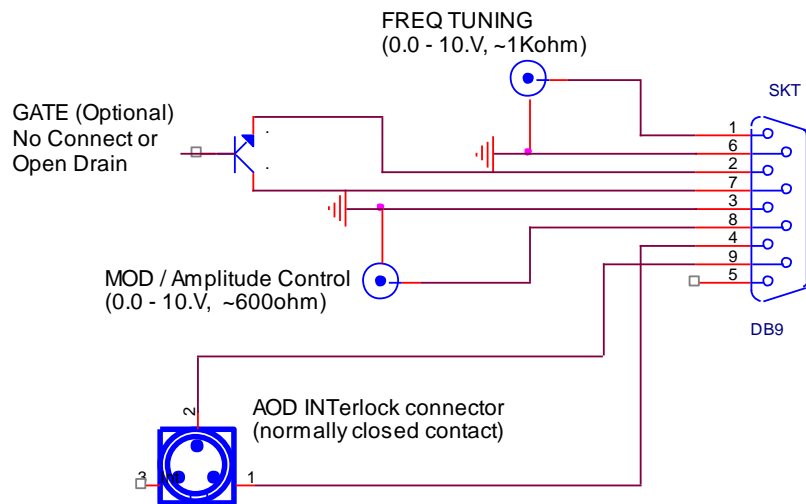

Figure 2b: Connection diagram

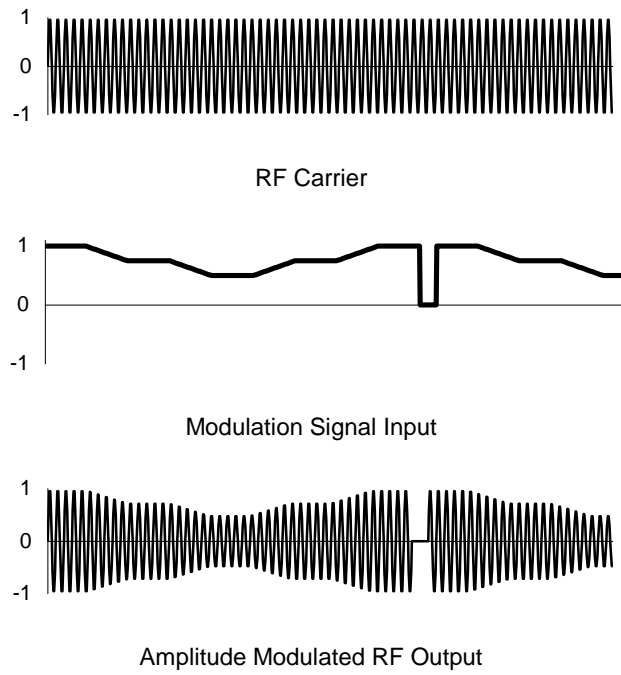
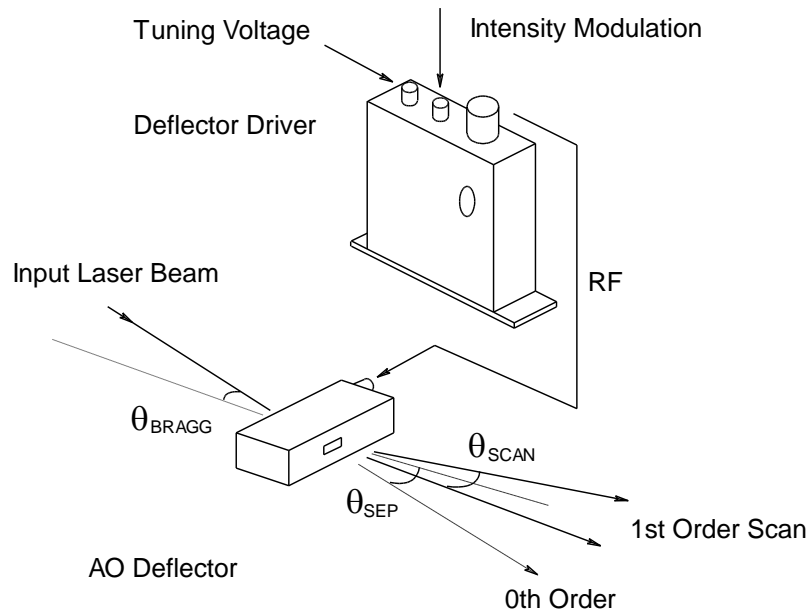

Figure 3: Typical Modulation Waveforms

Schematic of a basic acousto optic deflector and tunable driver



The input Bragg angle, relative to a normal to the optical surface and in the plane of deflection is given by:

$$\theta_{BRAGG} = \frac{\lambda \cdot fc}{2 \cdot v}$$

The separation angle between the zeroth order and mid scan point of the first order is given by:

$$\theta_{SEP} = \frac{\lambda \cdot fc}{v}$$

The first order scan angle is given by:

$$\theta_{SCAN} = \frac{\lambda \cdot \delta f}{v}$$

The access time or time aperture is given by:

$$T_{acc} = d/v$$

where : λ	=	wavelength	
δf	=	scan frequency bandwidth	
fc	=	centre frequency	
v	=	acoustic velocity of the crystal material	
		Quartz	5.7mm/usec
		Germanium	5.5mm /usec
d	=	beam diameter	

Figure 4: Deflector Parameters

If applicable, Coolant circuit not shown for clarity.

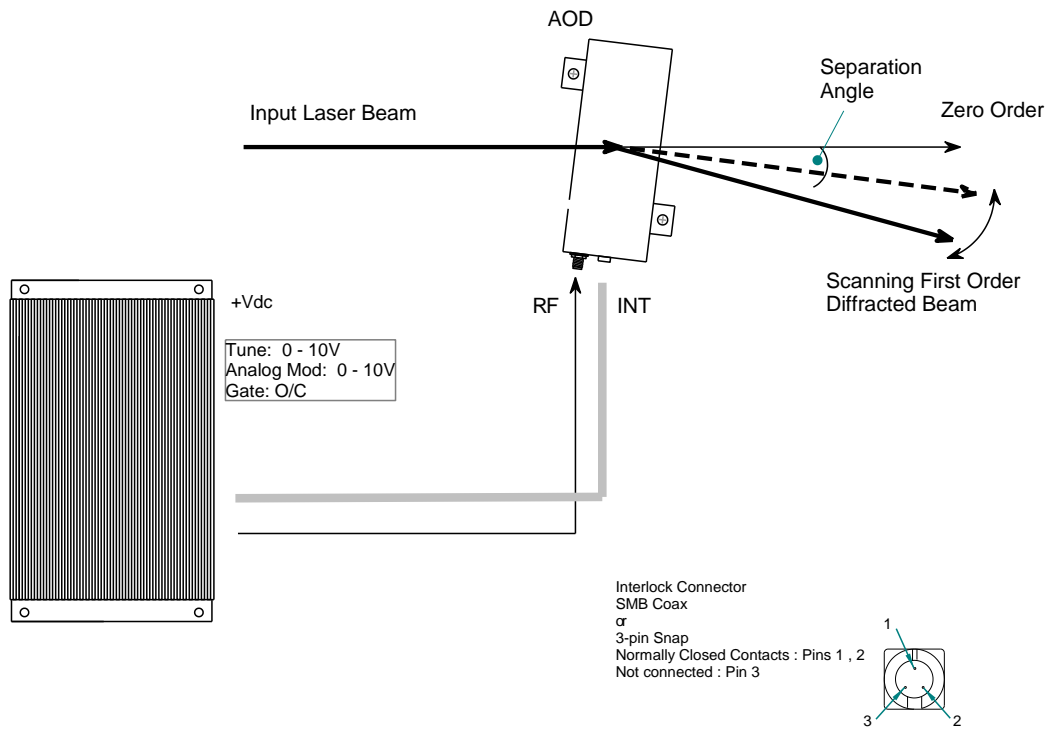

Orientation options

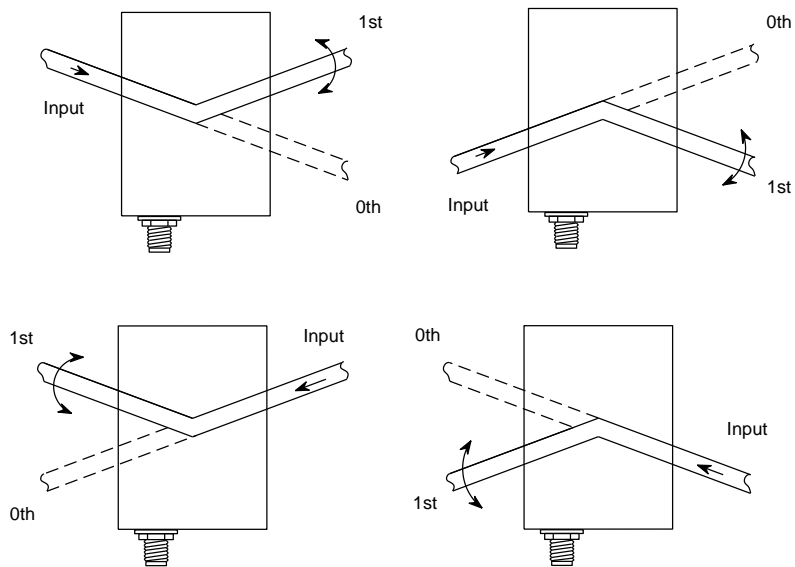

Figure 5: Typical orientations